

Name: \_\_\_\_\_ Date: \_\_\_\_\_



Manipulatives and Symbols

Draw a dot card to match the number.

Example



1

10

2

40

Copyright © 2014 Symphony Learning LLC. Permission is granted to reproduce this sheet for classroom use.



Name: \_\_\_\_\_ Date: \_\_\_\_\_



Manipulatives and Symbols

Draw a dot card to match the number.

1



30

2



60

3



70

4



50

Copyright © 2014 Symphony Learning LLC. Permission is granted to reproduce this sheet for classroom use.



Name: \_\_\_\_\_ Date: \_\_\_\_\_



Manipulatives and Symbols

Draw a dot to match the number.

Example

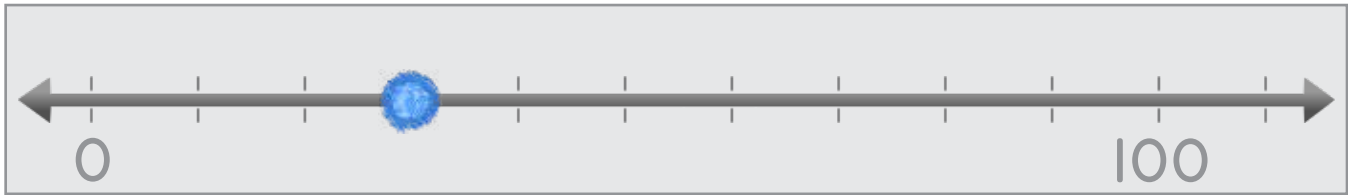

30

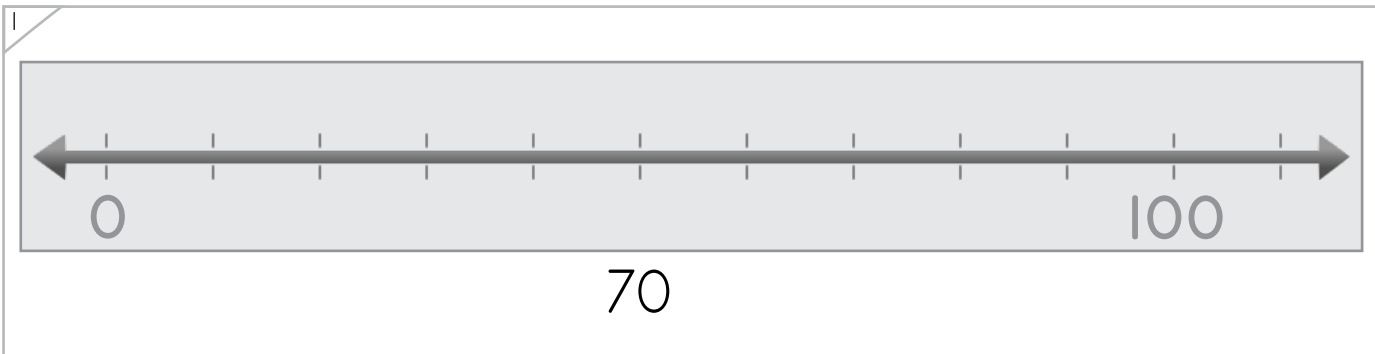

70

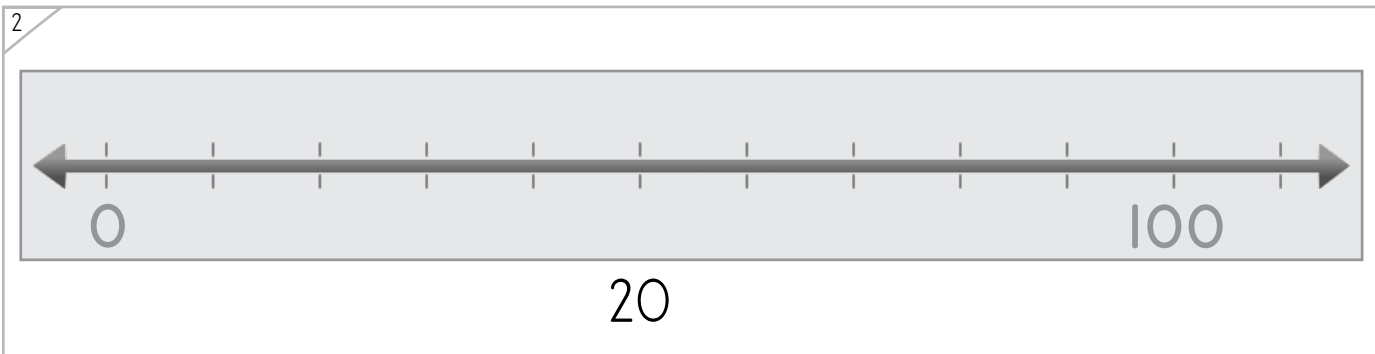

20

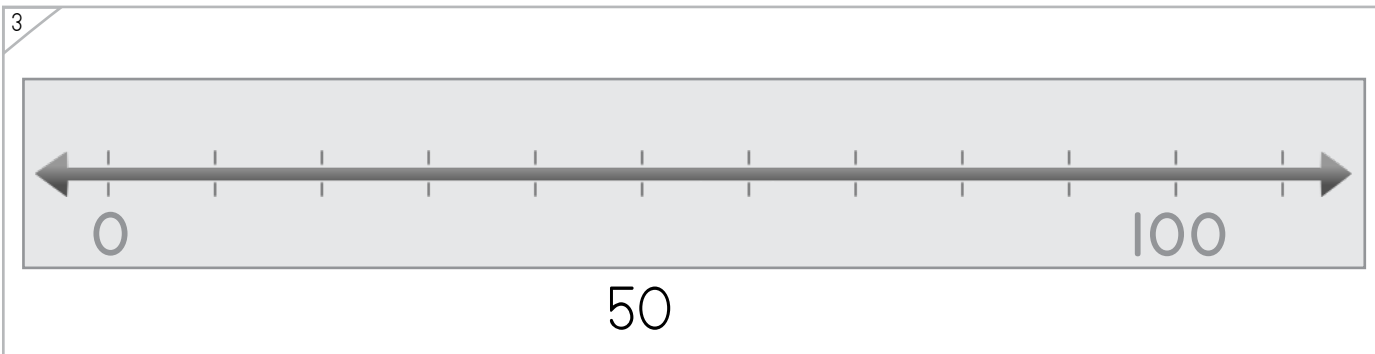

50

Copyright © 2014 Symphony Learning LLC. Permission is granted to reproduce this sheet for classroom use.



Name: \_\_\_\_\_ Date: \_\_\_\_\_



Manipulatives and Symbols

Write the missing number.

Example

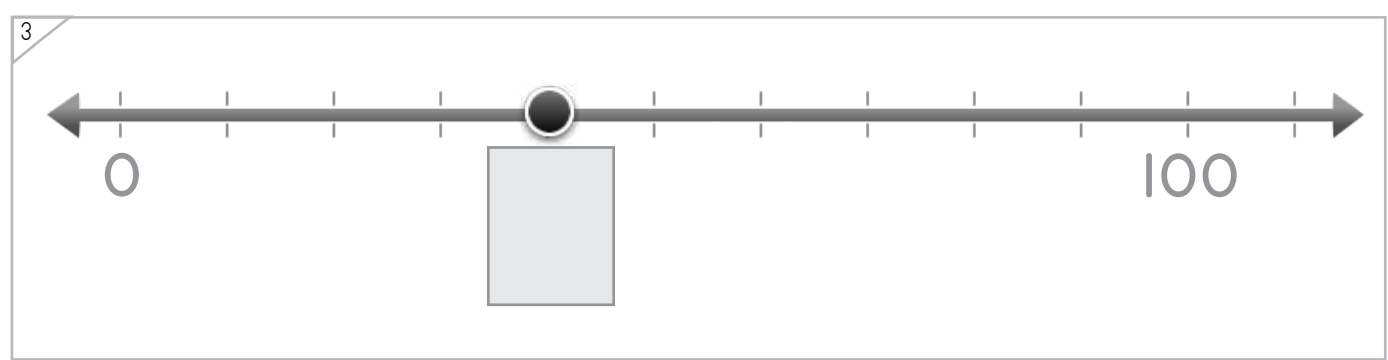
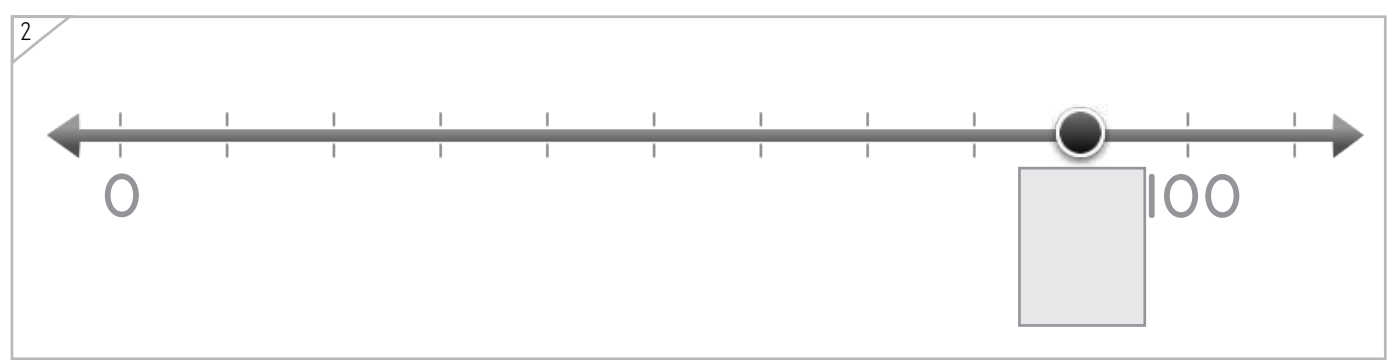
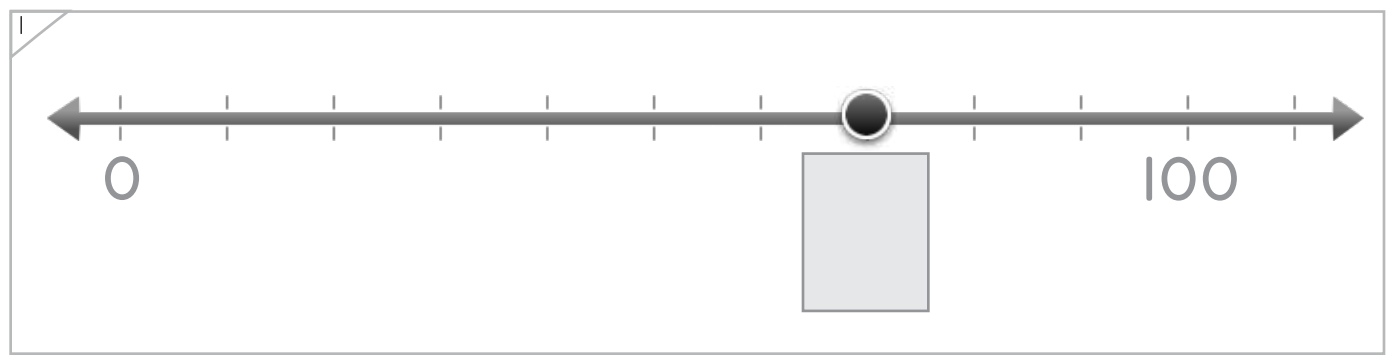
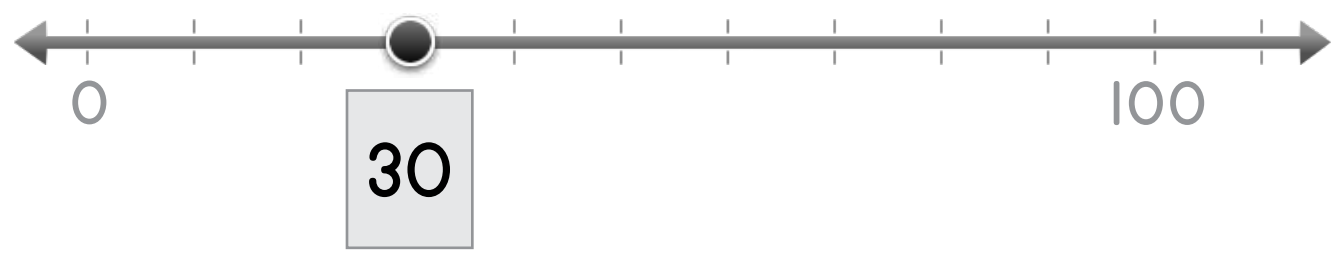

Copyright © 2014 Symphony Learning LLC. Permission is granted to reproduce this sheet for classroom use.



Name: \_\_\_\_\_

Date: \_\_\_\_\_

Draw a bar to match the number.

Example



Manipulatives and Symbols

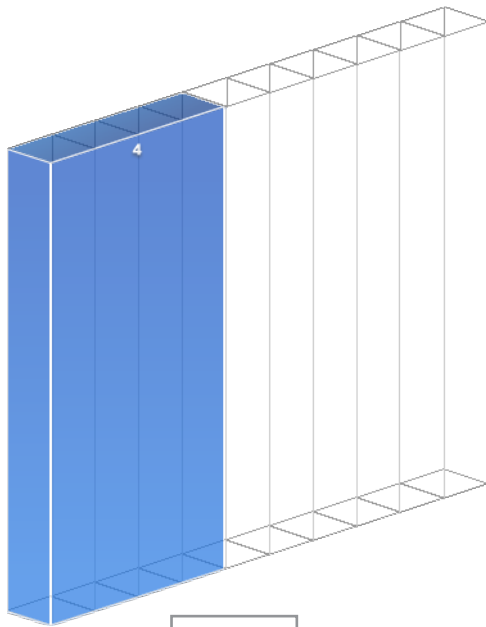

40

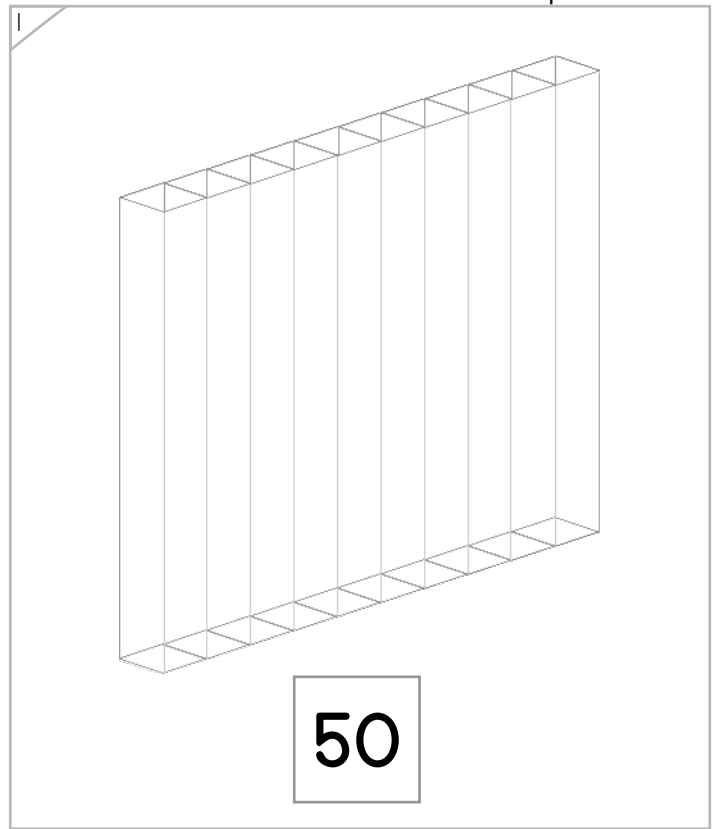

50

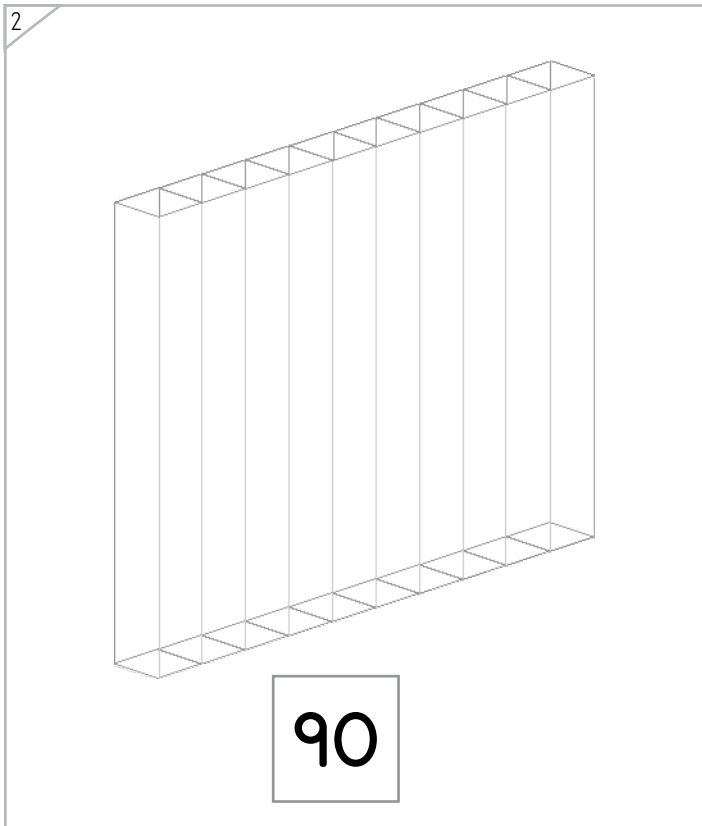

90

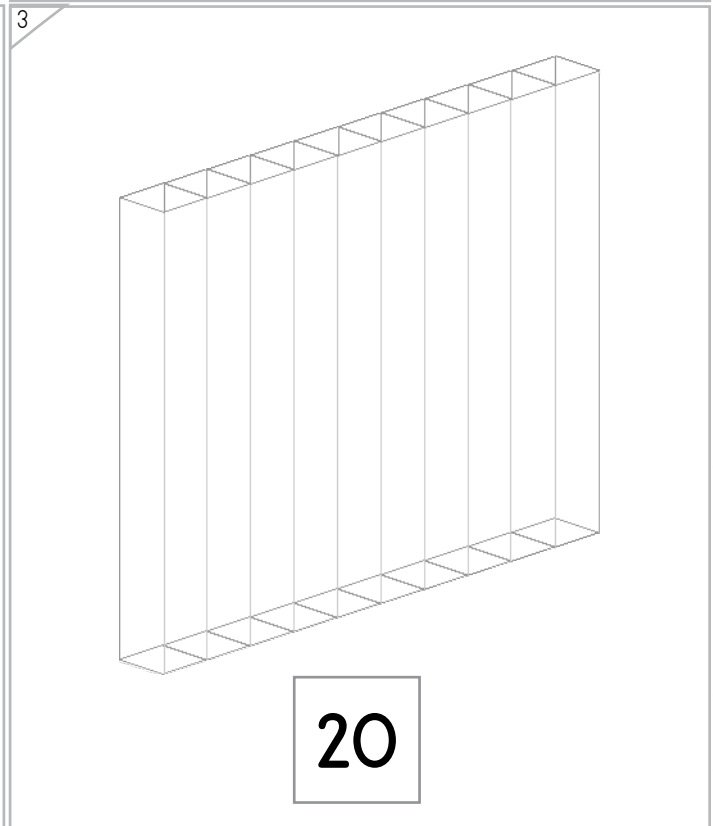

20

Copyright © 2014 Symphony Learning LLC. Permission is granted to reproduce this sheet for classroom use.



Name: \_\_\_\_\_ Date: \_\_\_\_\_

Draw a number to match the bar.

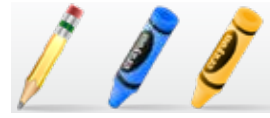

Manipulatives and Symbols

Example

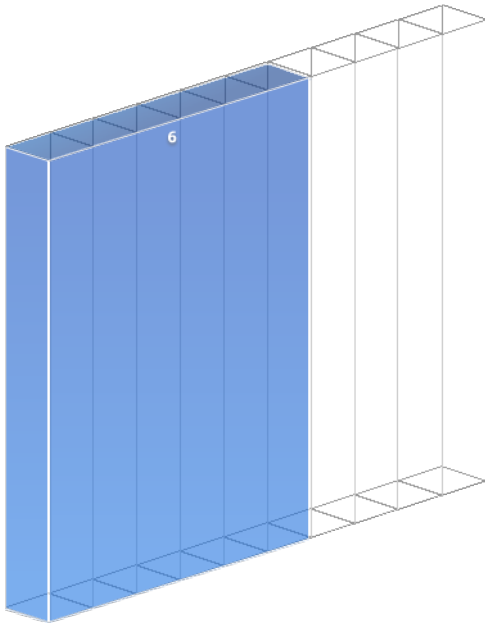

60

1

2

3

Copyright © 2014 Symphony Learning LLC. Permission is granted to reproduce this sheet for classroom use.

