

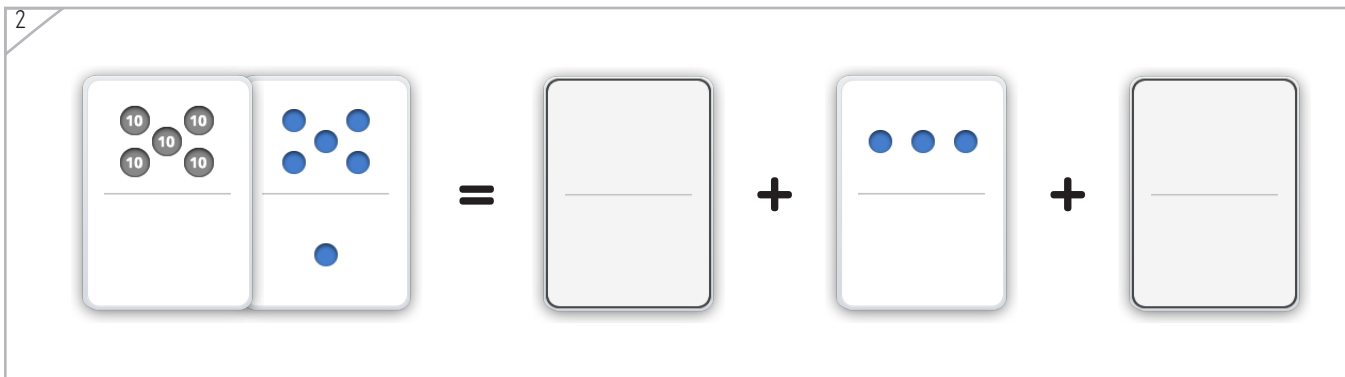

Manipulables

Dibuja una ficha que valga lo mismo que las otras dos juntas.

Ejemplo

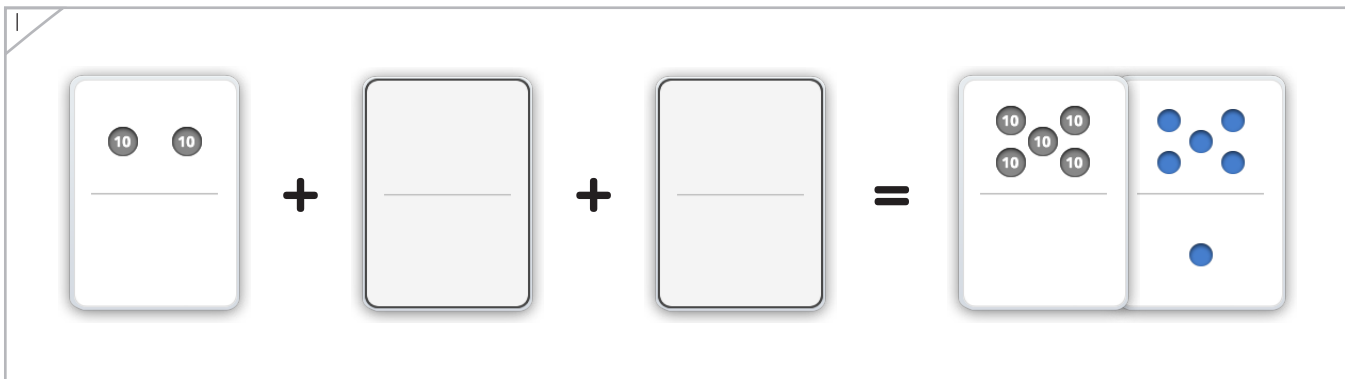
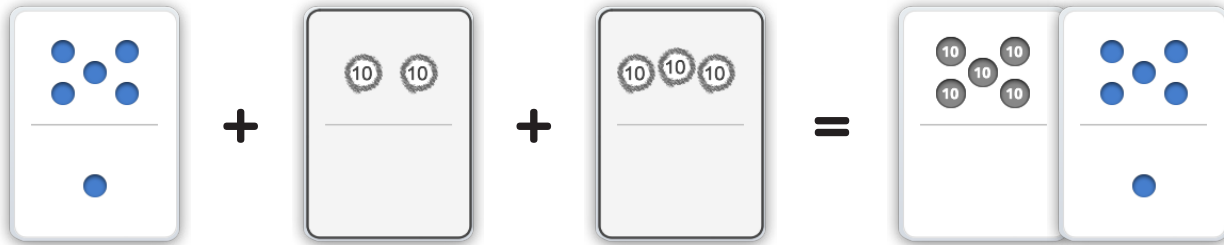



Manipulables

El punto salta tres veces. Escribe el número para completar la operación.

Ejemplo

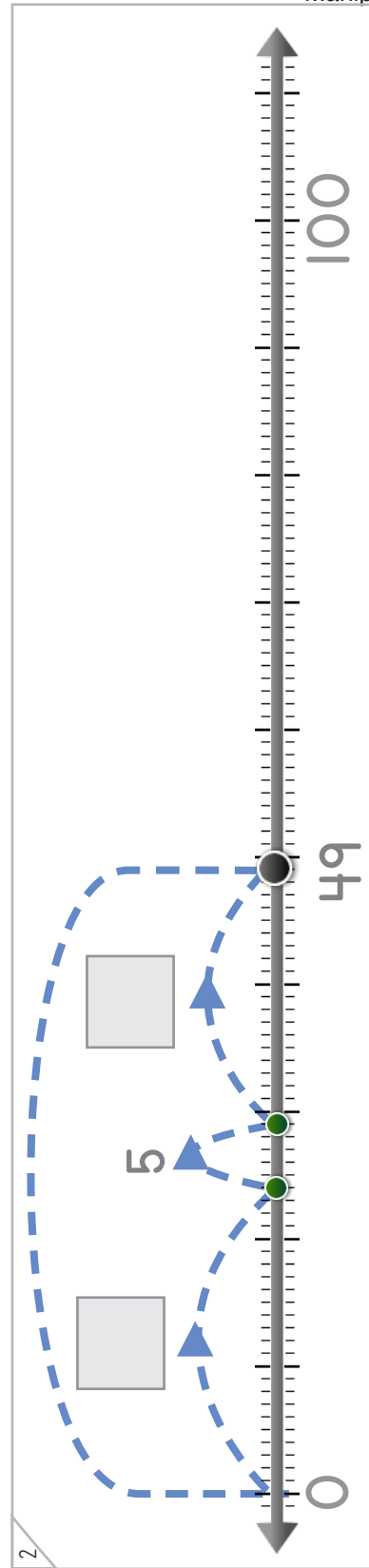
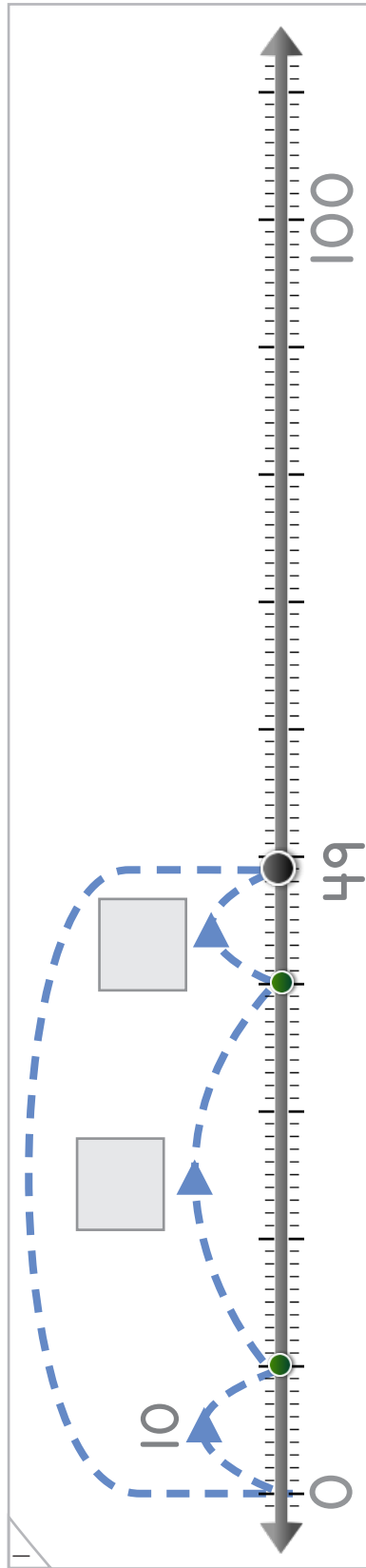
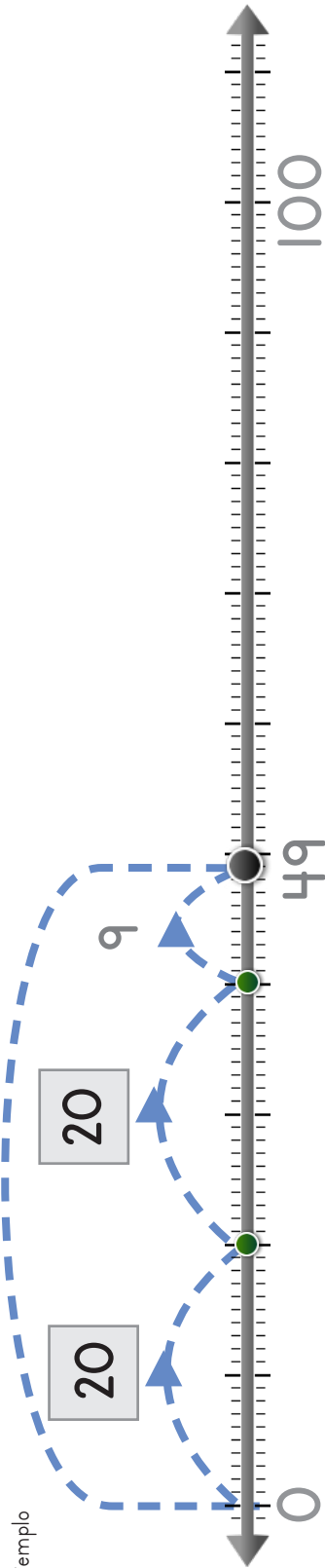

Dibuja la barra para completar la operación.

Ejemplo

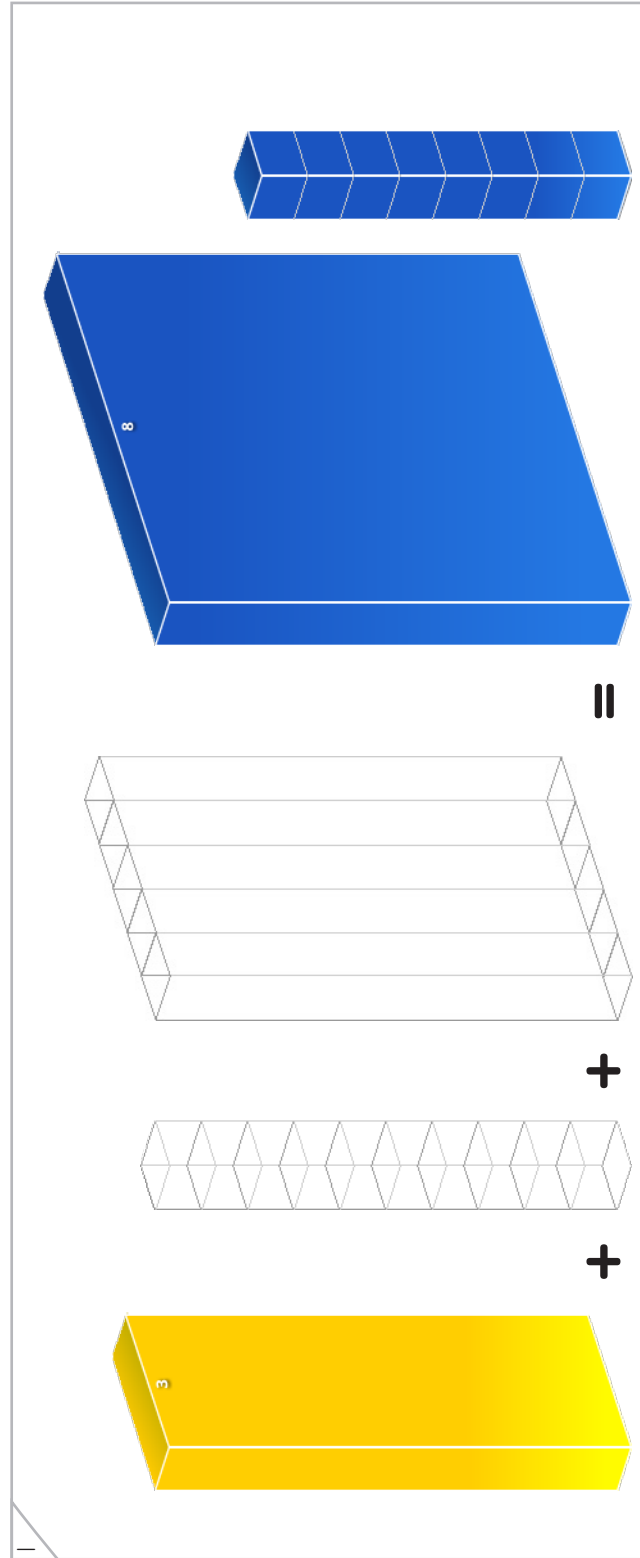
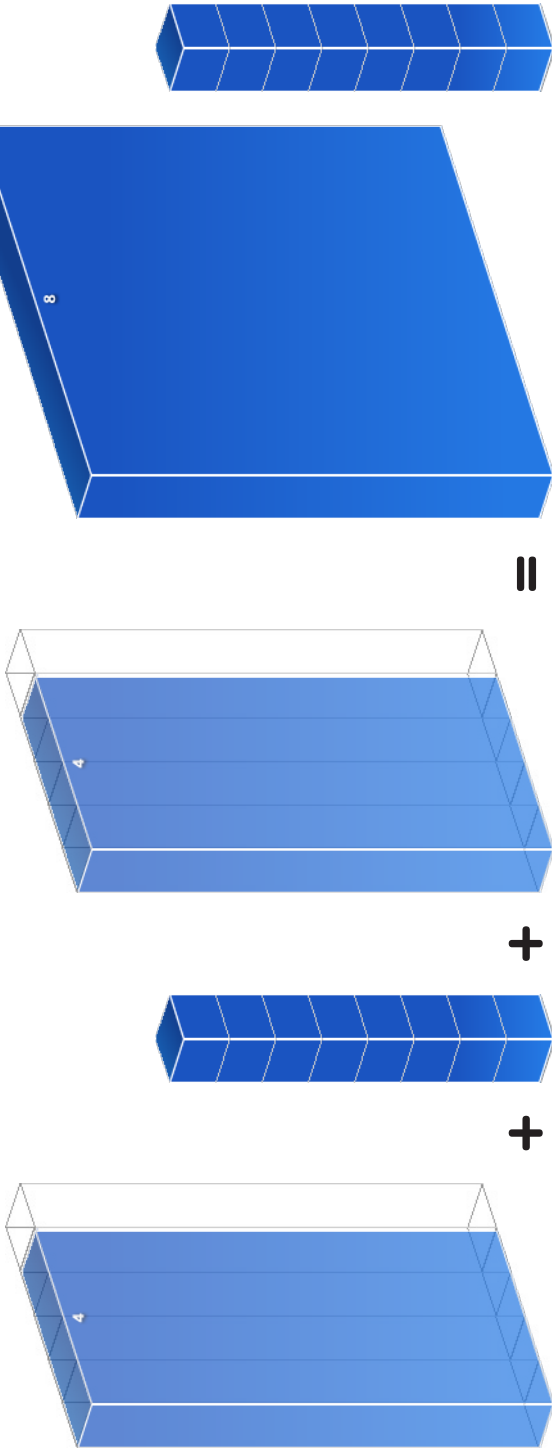



Completa cada operación.

$\square + 40 + \square = 73$
$3 + \square + \square = 73$
$73 = 30 + \square + \square$

$\square + 10 + \square = 38$
$8 + \square + \square = 38$
$38 = 6 + \square + \square$

$96 = \square + 6 + \square$
$\square + \square + 50 = 96$
$96 = 5 + \square + \square$

$52 = \square + 2 + \square$
$\square + \square + 30 = 52$
$52 = 1 + \square + \square$

