

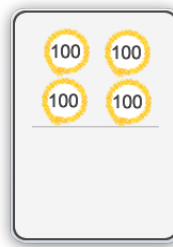

Dibuja la ficha que sea "100 más".

Ejemplo

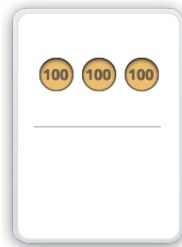

1

2

3

4





Manipulables

Dibuja el punto que sea "100 más".

Ejemplo

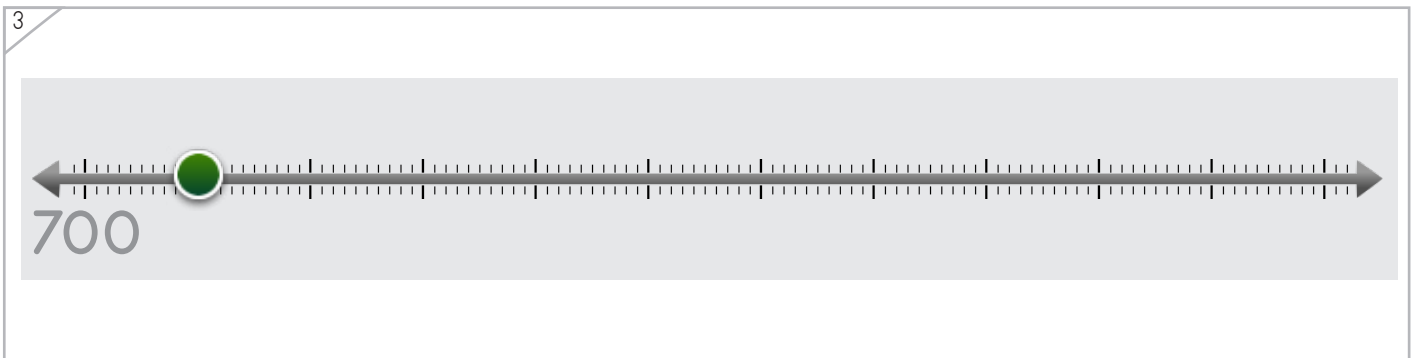
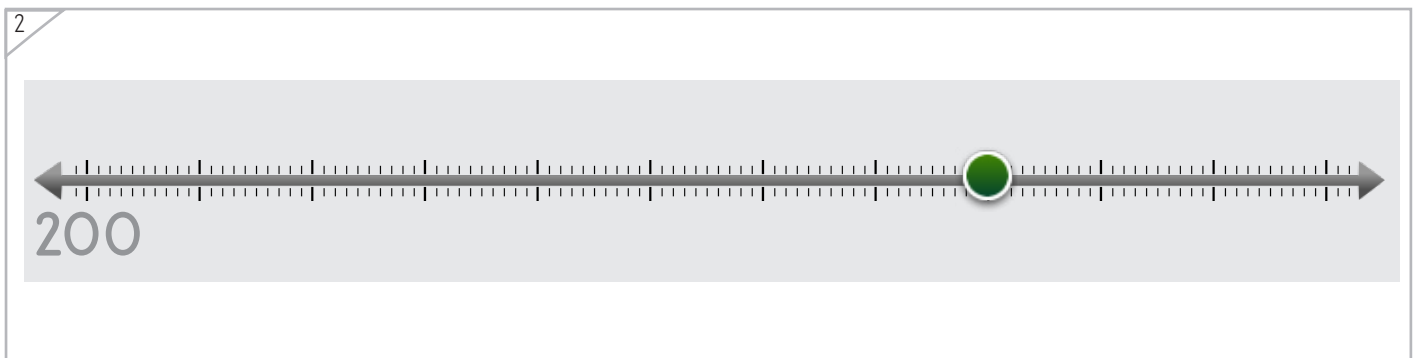
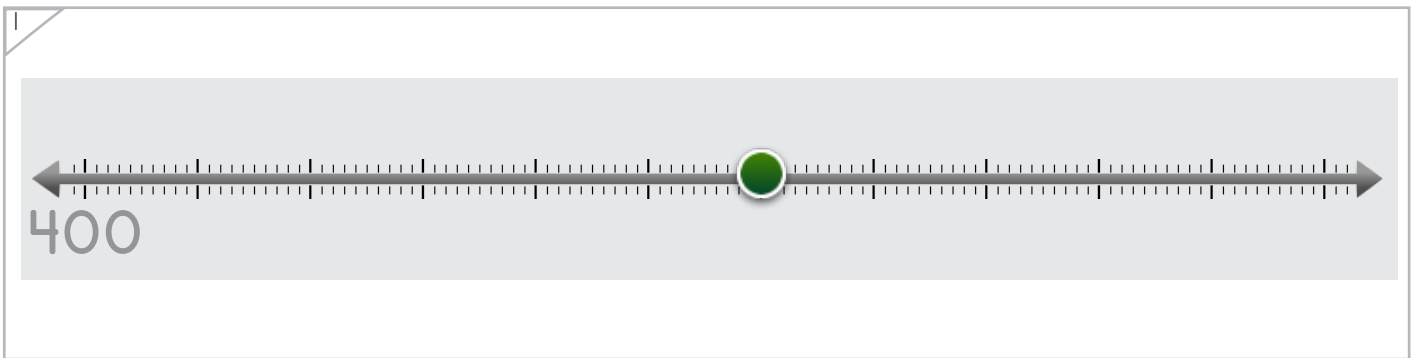
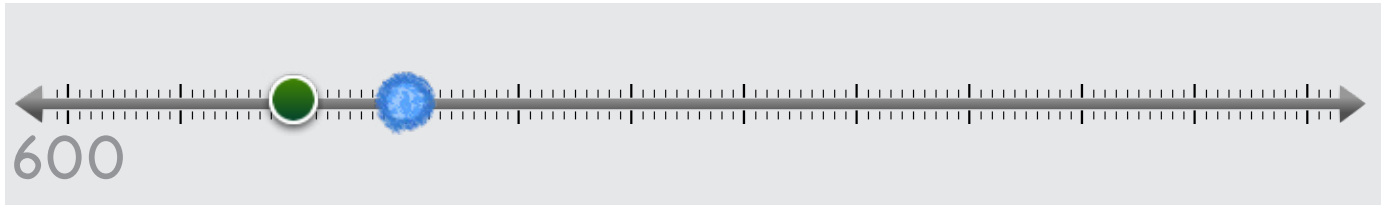

Copyright© 2017 Symphony Learning LLC. Se concede permiso para reproducir esta hoja para uso en el aula.





Dibuja la barra que sea "100 más".

Ejemplo

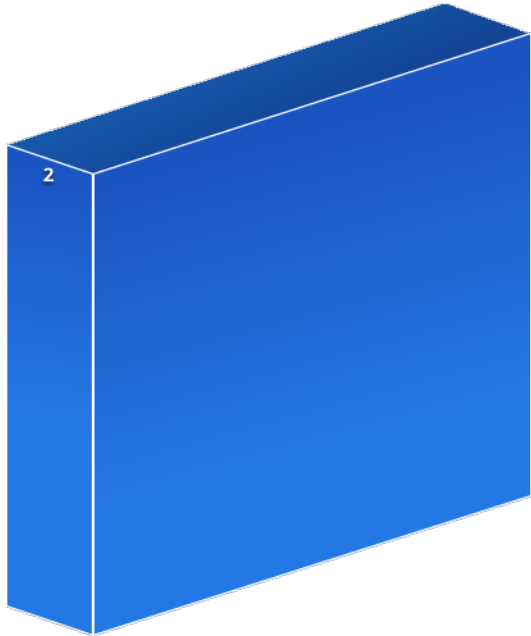

,

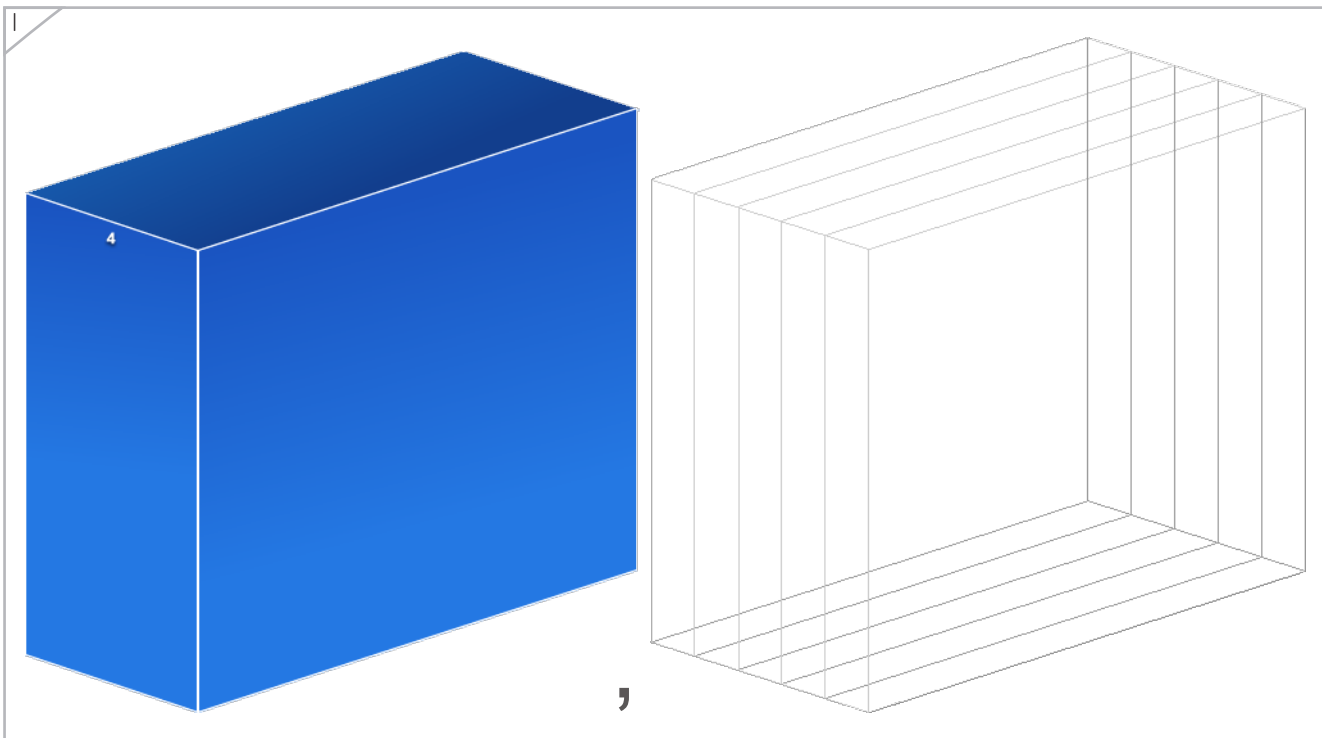
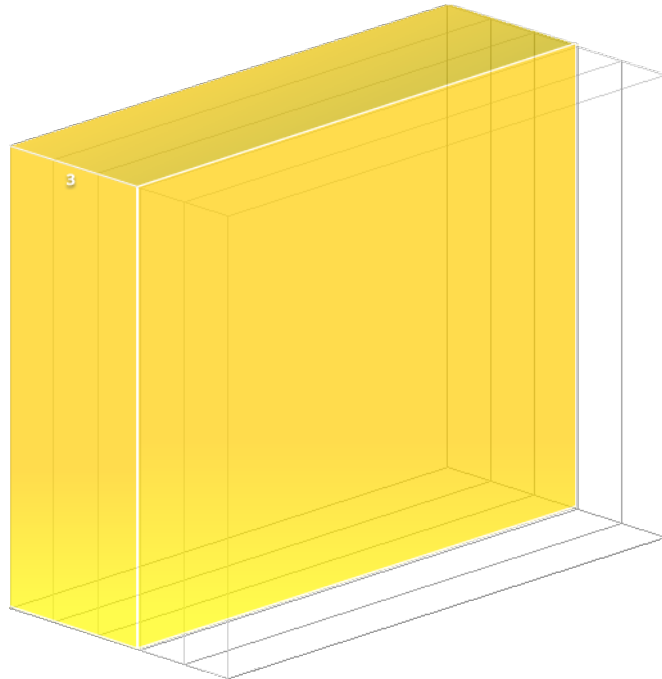



Escribe el número que sea "100 más".

300	<input type="text"/>
-----	----------------------

800	<input type="text"/>
-----	----------------------

600	<input type="text"/>
-----	----------------------

100	<input type="text"/>
-----	----------------------

0	<input type="text"/>
---	----------------------

200	<input type="text"/>
-----	----------------------

400	<input type="text"/>
-----	----------------------

500	<input type="text"/>
-----	----------------------





Escribe el número que sea "100 más".

700

0

200

100

500

200

600

800

